

CONNECTORS; WETMATE, 4-POLE.  
 BULKHEAD: MC-BH-4-M-SS, STAINLESS STEEL/MOLDED NEOPRENE, SEALING; 340 BAR OPEN FACE, 600 BAR MATED.  
 IN-LINE: MC-IL-4-F, MOLDED NEOPRENE WITH CABLE. LOCKING SLEEVE; MCDLS-F, DELRIN.

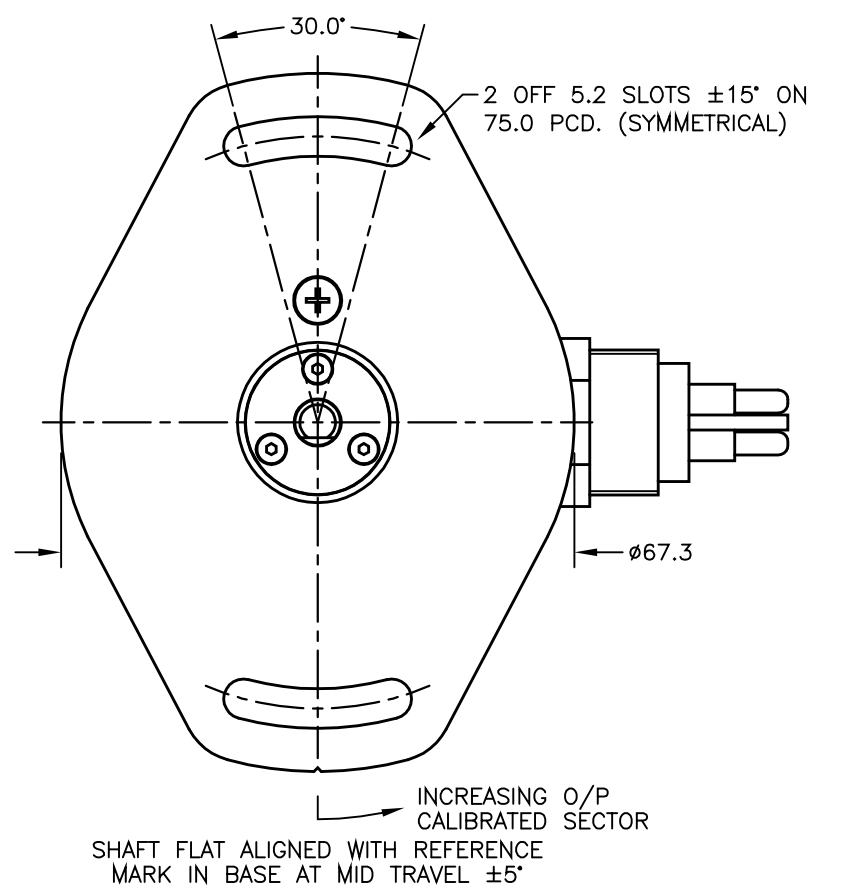

N.b. CONNECTOR ORIENTATION NOT GUARANTEED.

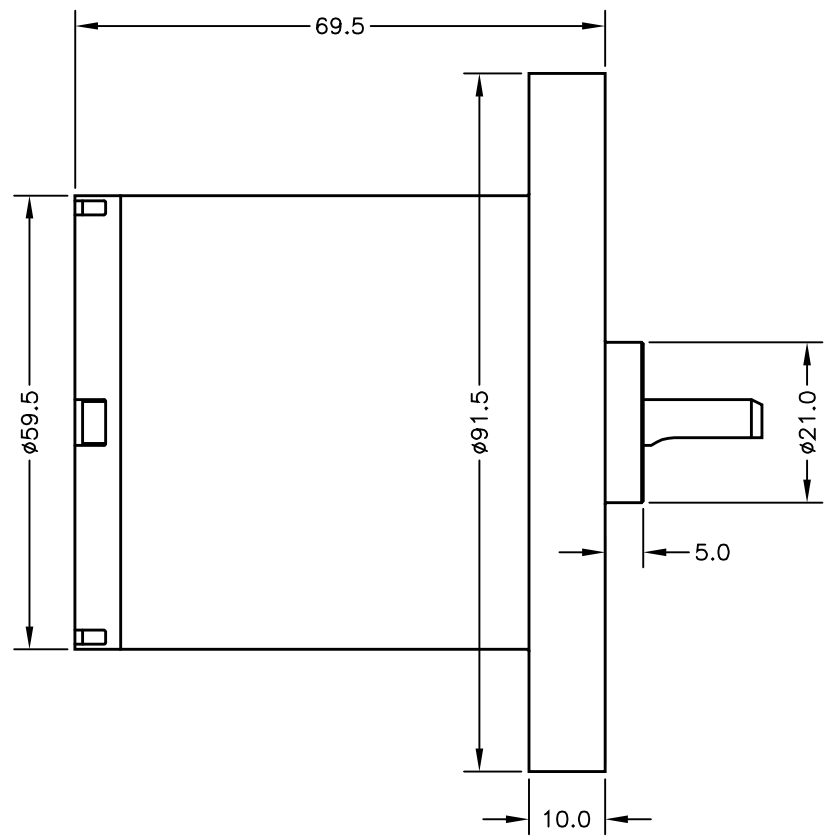
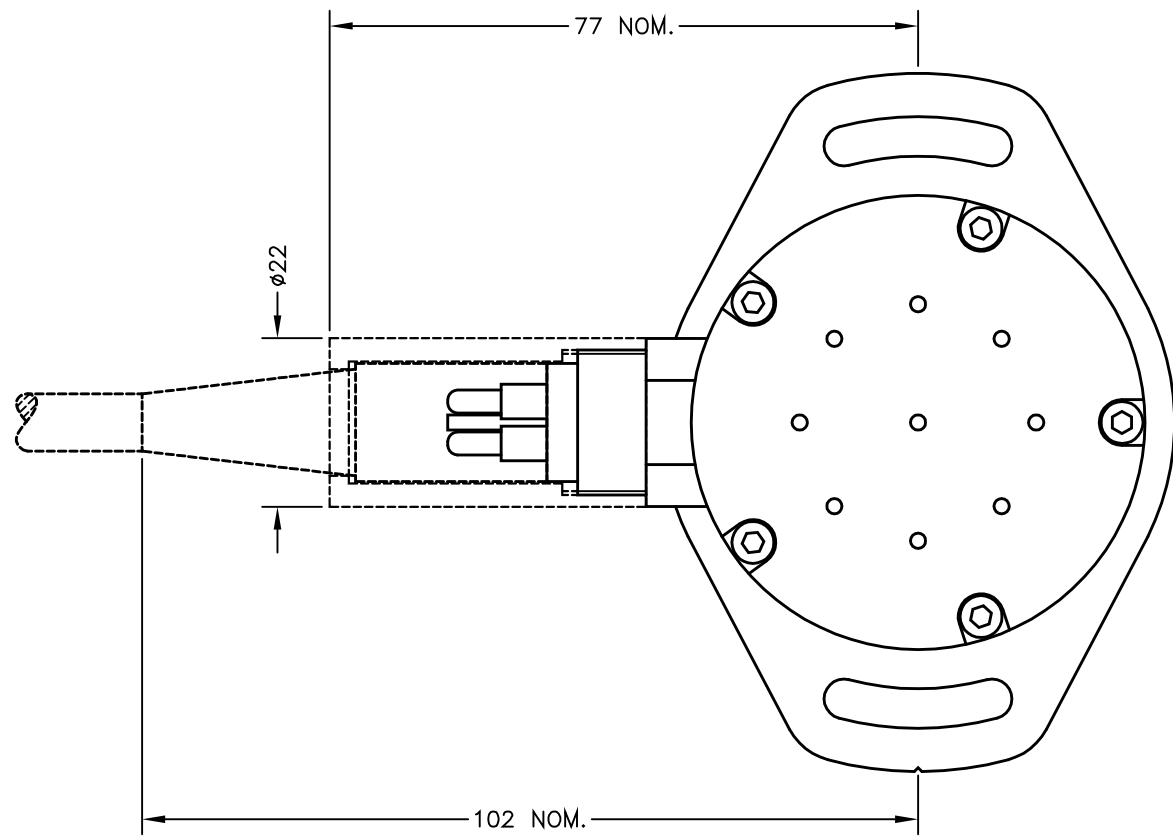
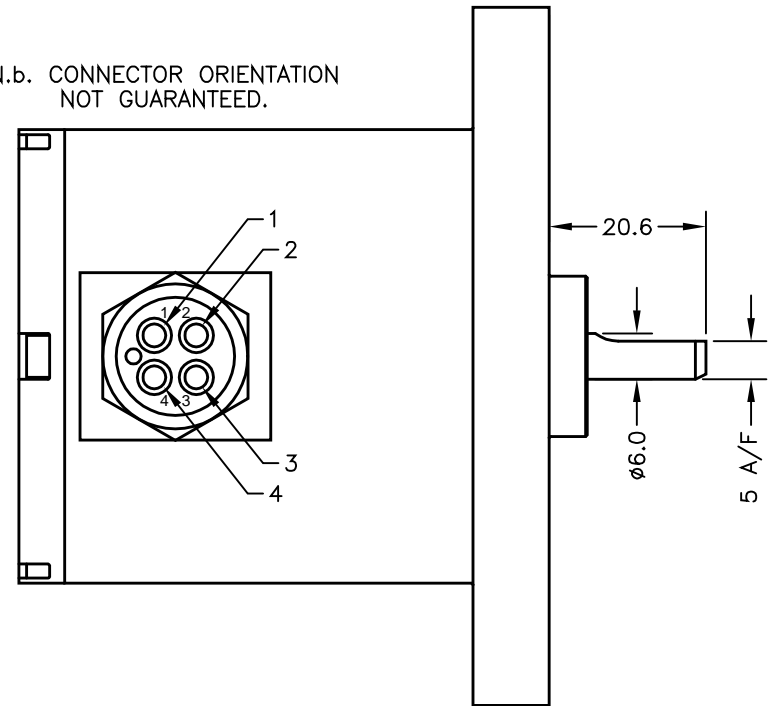

**ELECTRICAL OPTIONS/ SPECIFICATIONS**

OUTPUT OPTION	OUTPUT	SUPPLY	
A	0.5 TO 4.5V RATIO METRIC	5V	STANDARD
B	$\pm 5V$	$\pm 15V$	
C	0.5 TO 9.5V	24V	BUFFERED
D	$\pm 10V$	$\pm 15V$	
G	0.5 TO 4.5V	24V	
	SUPPLY CURRENT 12mA TYP. 20mA MAX.		
E	4 TO 20mA 2-WIRE	24V	
F	4 TO 20mA 3-WIRE SINK	24V	
H	4 TO 20mA 3-WIRE SOURCE	24V	

SINK VERSION OUTPUT COMPLIANCE 5-28V  
 SOURCE VERSION DRIVE 300Ω MAX TO 0V

MATING CONNECTOR SUPPLIED WITH 50cm MOULDED CABLE AS STANDARD.  
 4-CORE SCREENED: 0.5mm<sup>2</sup>,  $\phi 7.5$ mm MAX. JACKET / CORE INSULATION: EPDM.

CONNECTIONS:-

- 1 BLACK OUTPUT
- 2 WHITE 0V
- 3 RED BODY (OPTIONS: A, C, E-H)  
-Ve (OPTIONS: B OR D)
- 4 GREEN +Ve  
SCREEN NOT CONNECTED TO SENSOR

RANGE OF DISPLACEMENT FROM 0-15° TO 0-160° e.g. 76°, IN INCREMENTS OF 1°.  
 BODY MATERIAL:- STAINLESS STEEL 316.

A	FIRST ISSUE.	PDM
B	DISP. FROM 15° WAS 16° - RAN1146	PDM
C	CABLE COLOURS CORRECTED - RAN1190	PDM
D	RANGE NOTE AMENDED - RAN1200	PDM



DRAWINGS NOT TO BE CHANGED WITHOUT REFERENCE TO THE CHANGE PROCEDURE.  
 CHANGES TO PARTS USED IN INTRINSICALLY SAFE PRODUCT MUST BE APPROVED BY THE AUTHORISED PERSON  
 THIS IS AN UNCONTROLLED PRINT AND WILL NOT BE UPDATED.

MAXIMUM WORKING DEPTH: 3500 METRES 350 BAR. WHERE THE FREE END OF THE CABLE IS TO BE TERMINATED IN A SUBMERGED POSITION, ADEQUATE SEALING MUST BE PROVIDED TO PROTECT CONNECTIONS.  
 SENSOR IS OIL FILLED AND PRESSURE BALANCED. PRESSURE SENSITIVITY <math>< 1\%FS</math> TO 350 BAR

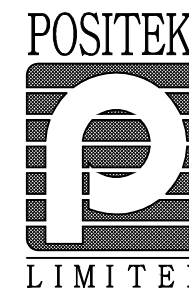

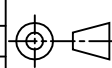
A	27/10/16	 CHECKED BY X ±0.4 RDS X.X ±0.2 X.XX ±0.1 DIMS mm
B	12/12/16	
C	14/06/17	
D	12/09/17	
DESCRIPTION		S520 350 BAR SUBMERSIBLE ROTARY SENSOR
SCALE 10mm		
DRAWING NUMBER S520-11		REV D
SHEET 1 OF 1		



# S520 SUBMERSIBLE ROTARY SENSOR

High-resolution angle feedback for industrial and scientific applications

- **Non-contacting inductive technology to eliminate wear**
- **Angle set to customer's requirement**
- **Durable and reliable**
- **High accuracy and stability**
- **Pressure balanced for use to 350 Bar in under water applications**



As a leading designer and manufacturer of linear, rotary, tilt and intrinsically safe position sensors, Positek® has the expertise to supply a sensor to suit a wide variety of applications.

Our S520 is an affordable, durable, high-accuracy rotary sensor designed for arduous underwater applications such as ROVs.

The S520, like all Positek® sensors, is supplied with the output calibrated to the angle required by the customer, between 15 and 160 degrees and with full EMC protection built in. The sensor provides a linear output characteristic proportional with the rotation of the input shaft, which has full 360 degree rotational freedom. There is a machined registration mark to identify the calibrated mid point.

Overall performance, repeatability and stability are outstanding over a wide temperature range. The S520 has long service life and environmental resistance with a rugged 316 stainless steel body and shaft. The flange mounting makes the sensor easy to install. There are a range of electrical options.

Environmental sealing is to IP68 350Bar

## SPECIFICATION

### Dimensions

Body Diameter	60 mm
Flange Diameter	92 mm
Body Length (to mounting face)	70 mm
Shaft	15 mm Ø 6 mm

*For full mechanical details see drawing S520-11*

**Independent Linearity**  $\leq \pm 0.25\%$  FSO @ 20°C - up to 100° travel

**Pressure Effects** Output changes with pressure  $< 1^\circ$

**Temperature Coefficients**  $< \pm 0.01\%/^\circ\text{C}$  Gain &

$< \pm 0.01\%$ FS/°C Offset

**Frequency Response**  $> 10$  kHz (-3dB)

$> 300$  Hz (-3dB) 2 wire 4 to 20 mA

**Resolution** Infinite

**Noise**  $< 0.02\%$  FSO

**Torque**  $< 20$  mNm Static

**Environmental Temperature Limits** (Non Icing)

Operating -4°C to +50°C

Storage -4°C to +50°C

**Sealing** Sealed to 350 Bar

**EMC Performance** EN 61000-6-2, EN 61000-6-3

**Vibration** IEC 68-2-6: 10 g

**Shock** IEC 68-2-29: 40 g

**MTBF** 350,000 hrs 40°C Gf

**Drawing List** S520-11 Sensor Outline

3D models, step or .igs format, available on request.

**Do you need a position sensor made to order to suit a particular installation requirement or specification? We'll be happy to modify any of our designs to suit your needs - please contact us with your requirements.**

For further information please contact:

[www.positek.com](http://www.positek.com) [sales@positek.com](mailto:sales@positek.com)

Tel: +44(0)1242 820027 fax: +44(0)1242 820615

Positek, Andoversford Industrial Estate, Cheltenham GL54 4LB. U.K.

S520-17f

1 of 2



# S520 SUBMERSIBLE ROTARY SENSOR

High-resolution angle feedback for industrial and scientific applications

## How Positek's technology eliminates wear for longer life

Positek's Inductive technology is a major advance in displacement sensor design. Our displacement transducers have the simplicity of a potentiometer with the life of an LVDT/RVDT. Our technology combines the best in fundamental inductive principles with advanced micro-electronic integrated circuit technology. A Positek sensor, based on simple inductive coils using Positek's ASIC control technology, directly measures absolute position giving a DC analogue output signal. Because there is no contact between moving electrical components, reliability is high and wear is eliminated for an exceptionally long life. It also overcomes the drawbacks of LVDT technology – bulky coils, poor length-to-stroke ratio and the need for special magnetic materials, no requirement for separate signal conditioning. We also offer a range of ATEX-qualified intrinsically-safe sensors.

S520	a	b	c	d
	Displacement	Output	K50	Z-code

a Displacement	Value	
Factory set to any angle from 0-16° (±8°) to 0-160° (±80°) (e.g. 0-54°)	<b>54</b>	
b Output	Code	
Supply V <sub>dc</sub> (tolerance)	Output	
+5V (4.5 - 5.5V)	0.5 - 4.5V (ratiometric with supply)	<b>A</b>
±15V nom. (±9 - 28V)	±5V	<b>B</b>
+24V nom. (13 - 28V)	0.5 - 9.5V	<b>C</b>
±15V nom. (±13.5 - 28V)	±10V	<b>D</b>
+24V nom. (18 - 28V)	4 - 20mA 2 wire	<b>E</b>
+24V nom. (13 - 28V)	4 - 20mA 3 wire Sink	<b>F</b>
+24V nom. (9 - 28V)	0.5 - 4.5V	<b>G</b>
+24V nom. (13 - 28V)	4 - 20mA 3 wire Source	<b>H</b>
Supply Current: 'A' 10mA nominal, 12mA max. 'B', 'D' & 'G' 12mA nominal, 15mA max. 'E' 26mA max. 'F' & 'H' 32mA nominal, 35mA max.		
c Connections	Code	
Connector radial IP68 350 Bar Wet mate 4 pin MC BH-4-M	<b>K50</b>	
Supplied with an over-moulded MC IL-4-F connector with 0.5 m, 4-core 20 AWG (0.5mm <sup>2</sup> ) EPDM cable assembly, and locking collar as standard.		
d Z-code (optional)	Code	
≤± 0.1% FSO @20°C Independent Linearity 0 - 16° min. to 0 - 100° max.	<b>Z650</b>	

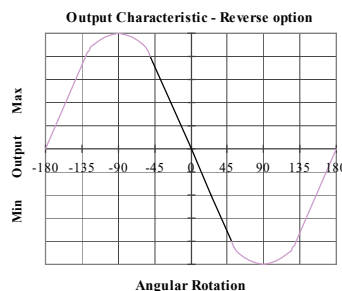
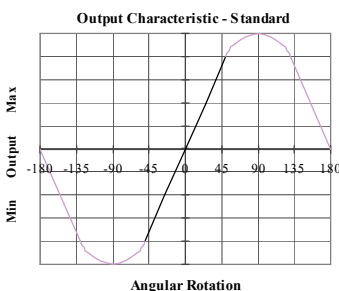

For further information please contact:

[www.positek.com](http://www.positek.com) [sales@positek.com](mailto:sales@positek.com)

Tel: +44(0)1242 820027 fax: +44(0)1242 820615

Positek, Andoversford Industrial Estate, Cheltenham GL54 4LB. U.K.



# Installation Information

## S520 350 BAR SUBMERSIBLE ROTARY SENSOR

Output Option	Output Description:	Supply Voltage: $V_s$ (tolerance)	Load resistance: (include leads for 4 to 20mA O/Ps)
A	0.5 - 4.5V (ratiometric with supply)	+5V (4.5 - 5.5V)	$\geq 5k\Omega$
B	$\pm 5V$	$\pm 15V$ nom. ( $\pm 9 - 28V$ )	$\geq 5k\Omega$
C	0.5 - 9.5V	+24V nom. (13 - 28V)	$\geq 5k\Omega$
D	$\pm 10V$	$\pm 15V$ nom. ( $\pm 13.5 - 28V$ )	$\geq 5k\Omega$
E	4 - 20mA 2 wire Current Loop	+24V nom. (18 - 28V)	$\approx 0 - 300\Omega$ max. @24V $\sim 1.2$ to 6V across 300 $\Omega$ $\{R_L \text{ max.} = (V_s - 18) / 20^{-3}\}$
F	4 - 20mA 3 wire Sink	+24V nom. (13 - 28V)	$\approx 0 - 950\Omega$ max. @24V $\sim 3.8$ to 19V across 950 $\Omega$ $\{R_L \text{ max.} = (V_s - 5) / 20^{-3}\}$
G	0.5 - 4.5V	+24V nom. (9 - 28V)	$\geq 5k\Omega$
H	4 - 20mA 3 wire Source	+24V nom. (13 - 28V)	$\approx 0 - 300\Omega$ max. $\sim 1.2$ to 6V across 300 $\Omega$

Connector Pin Layout:  
MC BH 4 M (face view)

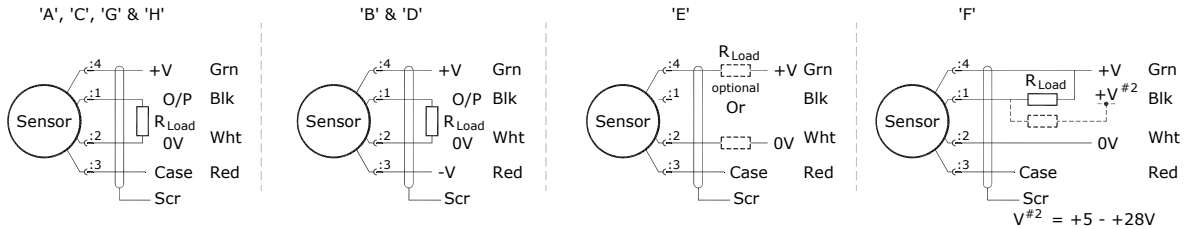

**Mechanical Mounting:** Flange mounted - see drawing S520-11. The sensor should be mounted with minimal axial and radial loading on the shaft for optimum life. It is recommended that the shaft is coupled to the drive using a flexible coupling. Tests indicate that life in excess of 16 million cycles can be achieved with 1kg side and end load. N.b. cable free end must be appropriately terminated to prevent water ingress into the cable. See page 2 for connector handling instructions.

**Warning Do not tamper with any of the case screws; the oil fill will be compromised.**

**Output Characteristic:** The sensor has full rotational freedom and two sectors, 180° apart, over which linear response can be achieved. At the mid point of the calibrated range the output signal will be half full scale deflection, and the flat on the shaft is aligned with the registration mark in the base of the sensor. In the calibrated range the output increases as the shaft is rotated in an anti-clockwise direction viewed from the shaft. The calibrated output is factory set to be between 15° and 160°.

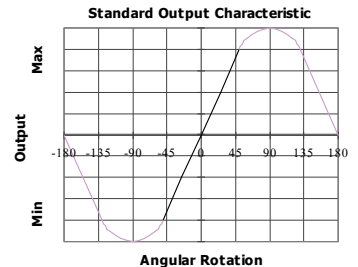

**Incorrect Connection Protection levels:-**

- A **Not protected** – the sensor is **not** protected against either reverse polarity or over-voltage. The risk of damage should be minimal where the supply current is limited to less than 50mA.
- B & D Supply leads diode protected. Output must not be taken outside  $\pm 12V$ .
- C & G Supply leads diode protected. Output must not be taken outside 0 to 12V.
- E, F & H Protected against any misconnection within the rated voltage.

For further information please contact:

[www.positek.com](http://www.positek.com) [sales@positek.com](mailto:sales@positek.com)

Tel: +44(0)1242 820027 fax: +44(0)1242 820615  
Positek, Andoversford Industrial Estate, Cheltenham GL54 4LB. U.K.



# Installation Information

## S520 350 BAR SUBMERSIBLE ROTARY SENSOR

### Connector Mating Instructions

#### Handling

- Always apply grease mating
- Disconnect by pulling straight, not at an angle
- Do not pull on the cable and avoid sharp bends at cable entry
- When using bulkhead connector, ensure that there are no angular load
- Do not over-tighten the bulkhead nuts
- Connectors should not be exposed to extended periods of heat or direct sunlight. If a connector becomes very dry, it should be soaked in fresh water before use

#### Cleaning

- General cleaning to remove any accumulated sand or mud on a connector should be performed using spray based contact cleaner (isopropyl alcohol)
- New grease must be applied again prior to mating

#### Greasing and mating above water (dry mate)

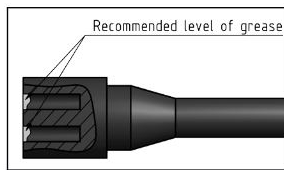

- Connectors must be greased with Molykote 44 Medium before every mating
- A layer of grease corresponding to approximately 1/10 of the socket depth should be applied to the female connector
- The inner edge of all the sockets should be completely covered, and a transparent layer of grease left visible on the face of the connector
- After greasing, fully mate the male and female connector in order to secure optimal distribution of grease on pins and in sockets
- To confirm that the grease has been sufficiently applied, demate and check for grease on every male pin. Then re-mate the connector

#### Greasing and mating under water (wet mate)

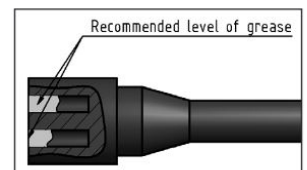

- Connectors must be greased with Molykote 44 Medium before every mating
- A layer of grease corresponding to approximately 1/3 of the socket depth should be applied to the female connector
- All sockets should be completely sealed, and a transparent layer of grease left visible on the face of the connector
- After greasing, fully mate the male and female connector and remove any excess grease from the connector joint

For further information please contact:

[www.positek.com](http://www.positek.com) [sales@positek.com](mailto:sales@positek.com)

Tel: +44(0)1242 820027 fax: +44(0)1242 820615

Positek, Andoversford Industrial Estate, Cheltenham GL54 4LB. U.K.